

# Introduction to Environmental Markets



## Green Aviation Master Class 4

Peter Durante

1-2 June 09



Shell Trading

# Shell Global CO2 Trading



## Emissions Trading – key points

- The trading system itself has a cap, which ensures the environmental outcome (unlike a tax)
- Price Discovery – allow the market to identify the most cost-effective means of reducing emissions
- Individual installations have an allowance, not really a cap. They can emit more than their allowance, but have to pay for the reduction of another installations' emissions.
- Must allocate shareholder capital to maximize return
- The decision to emit requires BOTH internal costs of abatement and the market price of allowances
- Emission reductions must eventually come from investments in new technology somewhere, though not necessarily from your installation



### Cap, but No Trade

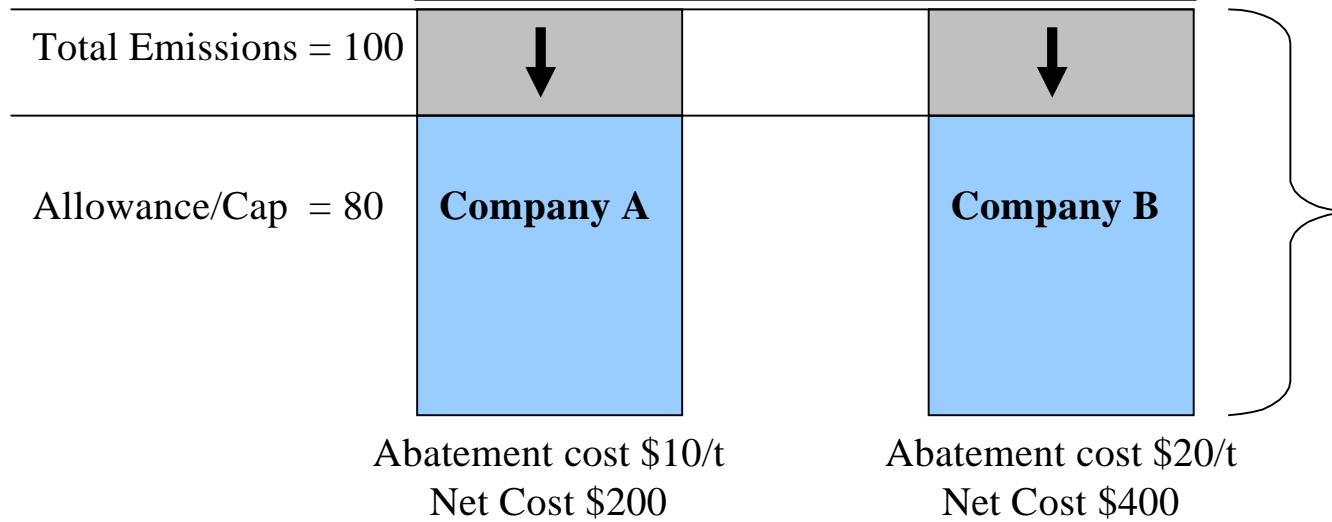

Total emission reduction = 40 tonnes

Total compliance cost = \$600

### Cap & Trade

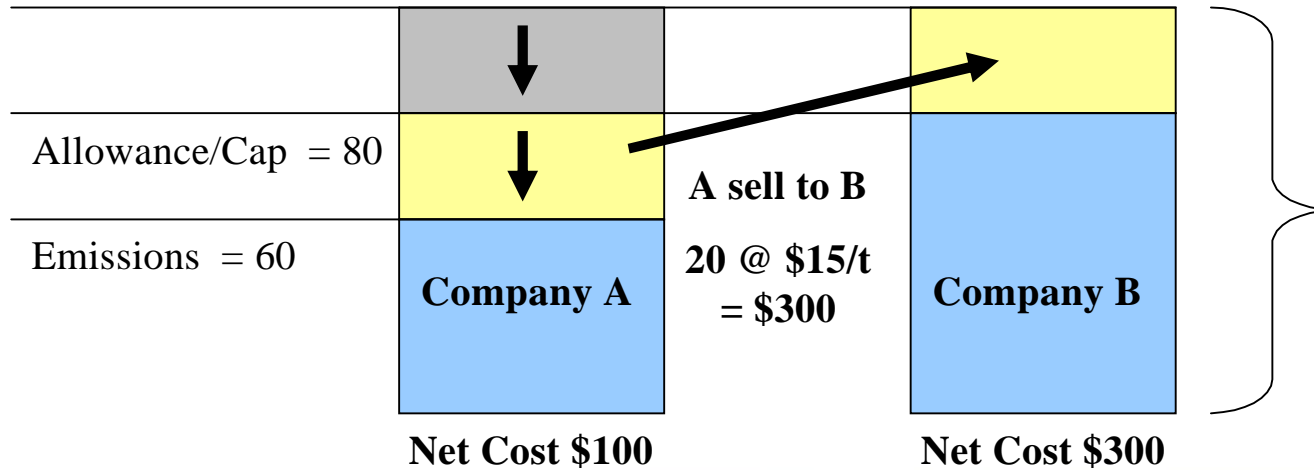

Total emission reduction = 40 tonnes

Total compliance cost = \$400



# The Kyoto Protocol provides three 'mechanisms' to reduce GHG emissions and meet targets; Emissions Trading, the CDM and the JI

## 'KYOTO' CREDITS

All greenhouse gases  
(CO<sub>2</sub>e)

**Allowance**

**S  
International  
Emissions  
Trading**

- Kyoto countries with targets are awarded allowances per tonne of CO<sub>2</sub>e emitted

**Assigned  
Amount Unit  
(AAU) = 1 tonne  
CO<sub>2</sub>e**

**EU ETS  
CO<sub>2</sub> only**

- Corporate level 'cap and trade' scheme

**European Union Allowance  
(EUA) = 1 tonne CO<sub>2</sub>e**

**Offsets**

**Clean  
Development  
Mechanism  
(CDM)**

- Credits awarded per tonne of emissions reductions in other Kyoto countries deemed as developing economies (non-Annex 1)

**Certified  
Emission  
Reduction (CER)  
= 1 tonne CO<sub>2</sub>e**

**Joint  
Implementation  
(JI)**

- Credits awarded per tonne of emissions reductions in another 'developed' (Annex 1) Kyoto country

**Emission Reduction  
Unit (ERU) = 1 tonne  
CO<sub>2</sub>e**

**CERs/ERUs may be used for  
EU ETS compliance from 2008  
and 2012 and in Phase III  
(2013-2020), though exact  
Phase III rules not yet known**



# CO<sub>2</sub> : A Global Business

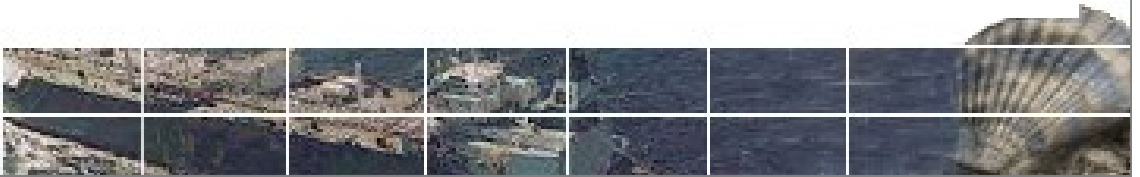
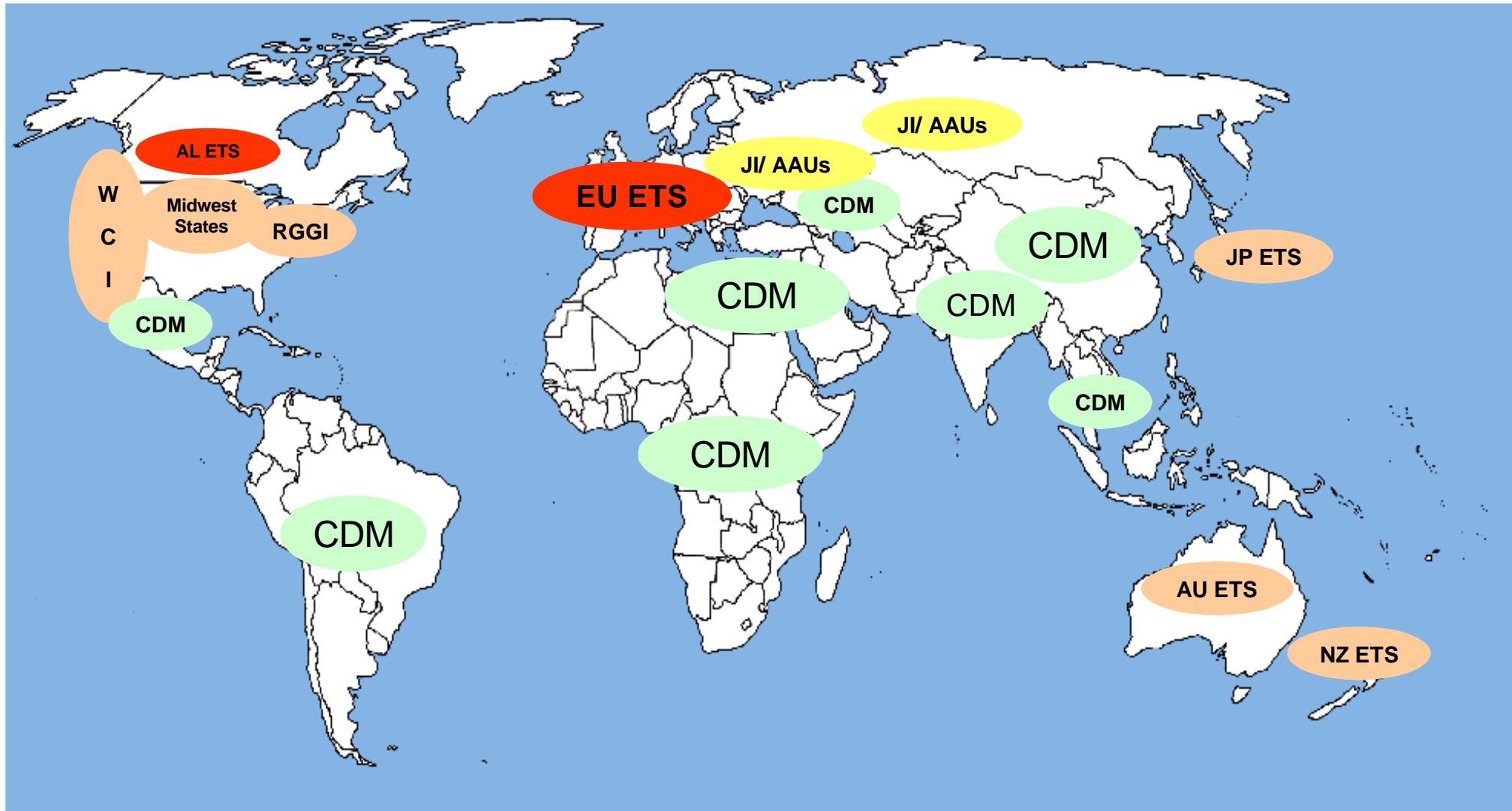

## The EU Emissions Trading Scheme (EU ETS) is a scheme for heavy industrial emitters and provides a market-based mechanism to help reduce emissions

### PRINCIPLE

- The EU ETS is a 'cap and trade' scheme in which installations are annually allocated an amount of CO<sub>2</sub> emission allowances
- Emitters monitor and annually report their CO<sub>2</sub> emissions and are obliged to surrender an amount of allowances equivalent to their emissions in that year
- If an installation has received more free allowances than it needs, it may sell them to anybody
- The scheme covers specific industries (e.g., pulp & paper, metals, power generation, cement, oil & gas) plus all combustion units above 20 MW
- Approximately 45% of EU CO<sub>2</sub> emissions are covered by the scheme

### STRUCTURE

- The scheme runs in two phases:
  - Phase I (2005 – 2007)
  - Phase II (2008 – 2012)
  - Phase III (2013 – 2020)
- In each of these phases, each member state allocates the annual allowance quantities to individual installations in its National Allocation Plan (NAP)
- In Phases I & II, most allowances were given to installations for free but in subsequent phases an increasing proportion will be auctioned
- Installations may use Kyoto offset credits in addition to their allocation of EU Allowances (EUAs) up to approximately 13.5% on average across the ETS, though this use may be restricted in Phase III



## EU ETS: Emissions by sector

Note – ‘Oil and Gas’ includes emissions from the production and refining of crude oil, not end use / combustion.

### Statistics

#### Total emissions for result set:

2005 : 2,010,868 ktonnes

2006 : 2,028,780 ktonnes

#### Total allowance for result set:

2005: -2,106,312 ktonnes

2006: 2,069,489 ktonnes

#### Total number of installations in result set:

10816

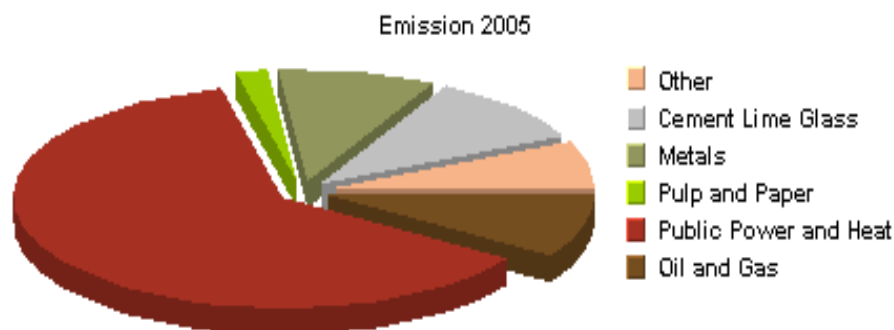
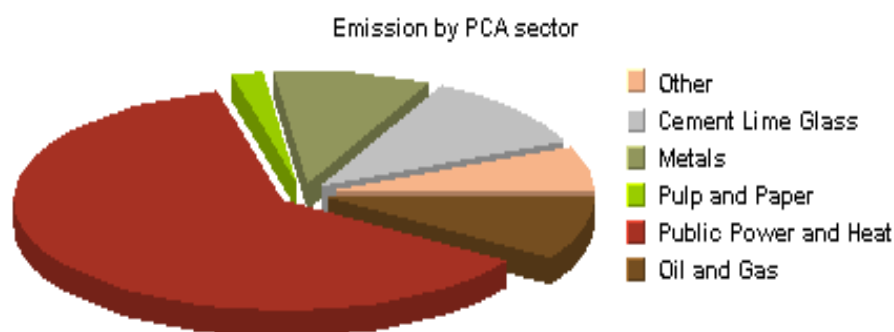

Source: Point Carbon



Much is said about the price of carbon in the EU ETS but the market is not yet properly understood by many companies

### EU ETS - EUA PRICES FUTURES CONTRACTS

Phase I: News of over-supply, and price collapses. Rational behaviour

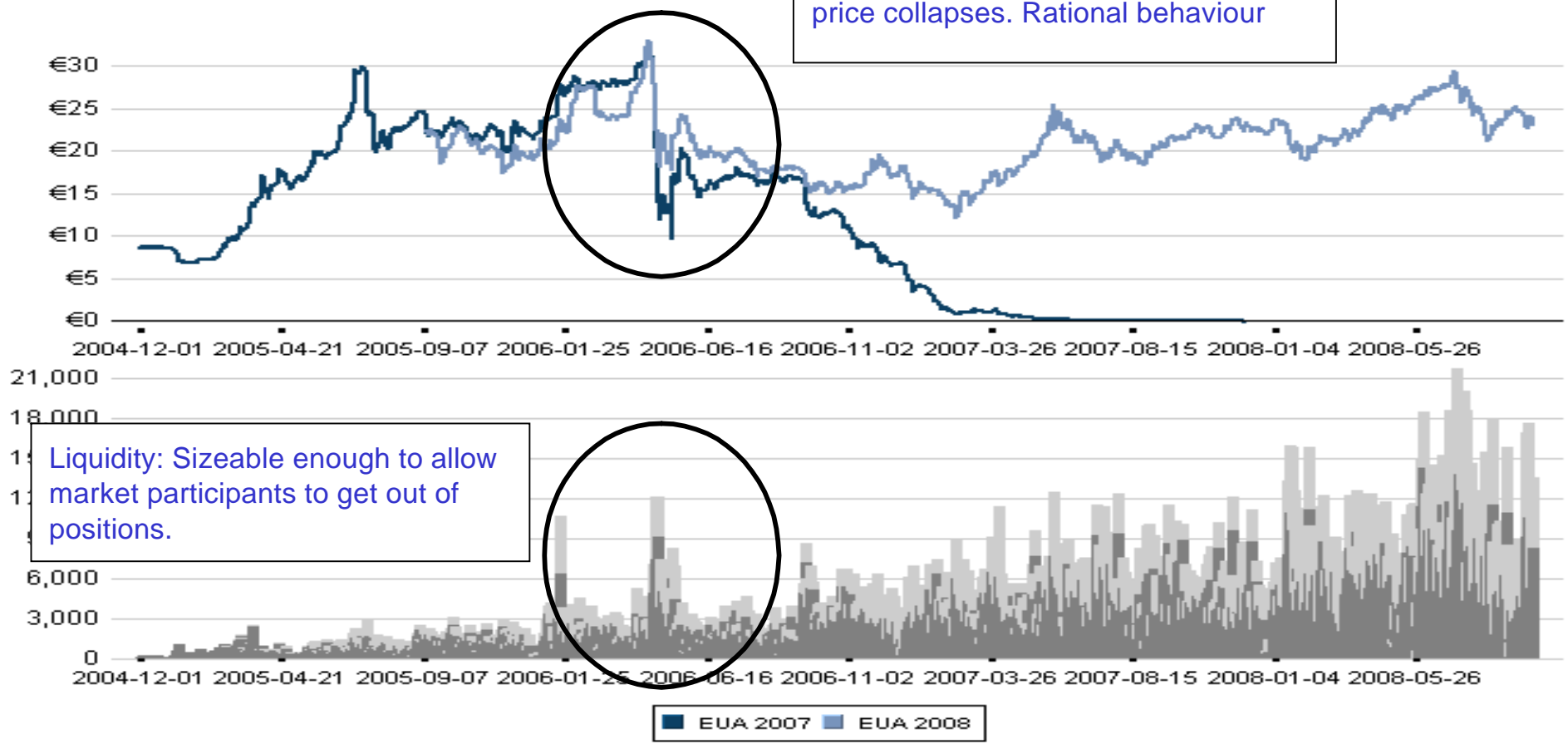

Liquidity: Sizeable enough to allow market participants to get out of positions.

Source:Point Carbon

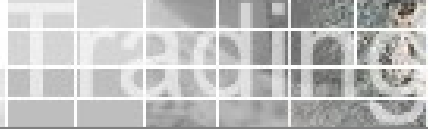

# EU ETS: Fundamentals and Price

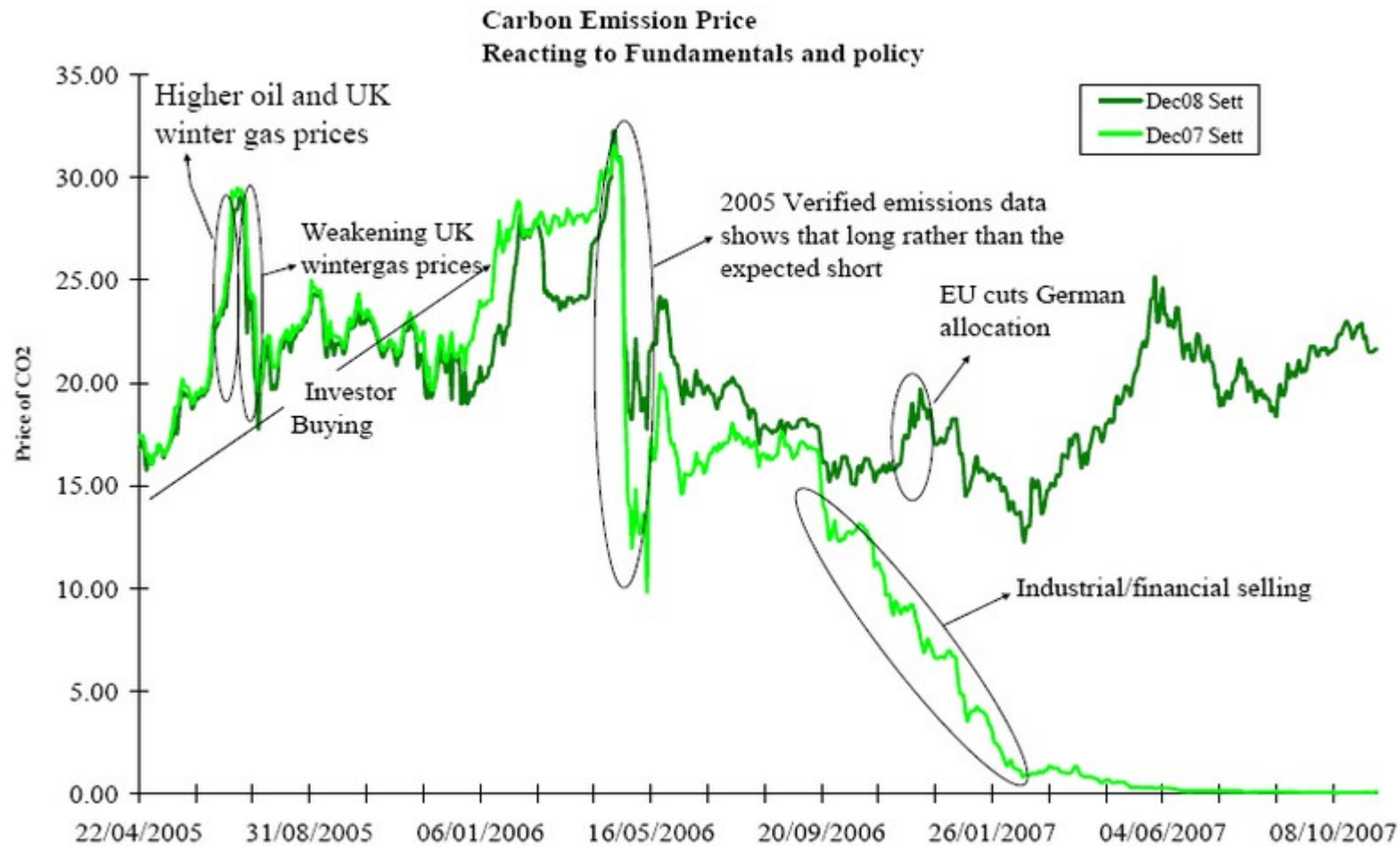

Source: UK FSA report "Emissions Trading Market: Risks and Challenges (Mar 08)



## Price & Trading Drivers

- The energy complex
- Correlations to other commodities / markets
  - Compliance asset or investment class?
- Short-term supply / demand balance
  - Fuel switching
  - CER hedging
- Macro-economics / state of the financial investment community
- Long-term supply / demand balance
  - Phase III dynamics
  - Son of Kyoto



## Price Projections: What are they good for?

- Generated by a host of institutions and analysts
  - Wide range of estimates and timeframes
  - €16, €21, €25, €30, €40, €60, etc
- Of varying use / accuracy
- Depends on one's perspective
  - Long-term investments
  - Phase II strategy
  - Daily switching price
  - How much can I make by lunch?



## EU ETS – How the market trades

OTC (brokered or bilateral) – Most common is to agree forward sale/purchase and ‘physical’ delivery

- Example: Counterparty X agrees to buy from Shell 1million EUAs for delivery on 1 Dec 2011 @ €15.50 / EUA. Deal done bilaterally, therefore no brokerage
- Example 2: Shell agrees to buy from Counterparty X 750k CERs for delivery on 1 Dec 2009 @ €12.13 via Broker Y, paying brokerage of €0.05/CER



# Emissions Exchanges

- Spot delivery and futures on EUAs and CERs
- ICE/ECX (pictured below) by far the most liquid
- Others include NYMEX, EEX, NYSE/BlueNext, Chicago Climate Exchange, NCDEX (India)

IntercontinentalExchange™ (ICE) - pdurante @ Shell

View Admin Help Logout

Kill All Activate All Live Only Hold Bids Hold All Hold Offers Excel

IPEG Futures Crack Jet Diffs CIFNWE + FOBMED Euro Gasoil + Diesel Diffs Fuel Oil ICE Heating Oil Futures MESC (Mid East Sour Crude) RBOB

Orders Deals EMISSIONS EXCH FUTURES WTI Brent - WTI Spreads IPE Brent IPE Gasoil IPEG Spread Matrix

Hold All On Hit/Lift Hold Bids On Hit Hold Offers On Lift Re-Link Agents History Formulas

Hub	Strip	+ -	Sell	Qty	Bid	Offer	Qty	Buy	High	Low	Last	Volume	WAP	Settle...	Kill	Qty	Bid	Offer	Qty	Kill
ECX	Dec08	+	Hit	7	24.86	24.91	1	Lift	25.35	24.83	24.88	2486	25.09	24.68						
ECX	Dec09	+	Hit	15	25.90	25.97	1	Lift	26.30	26.10	26.10	212	26.20	25.73						
ECX	Dec10	+	Hit	10	26.73	26.83	1	Lift	27.05	27.01	27.05	90	27.04	26.61						
ECX	Dec11	+	Hit	7	27.81	27.83	11	Lift	0.00	0.00		0	0.00	27.86						
ECX	Dec12	+	Hit	10	29.20	29.27	1	Lift	29.55	29.20	29.20	164	29.43	28.98						
ECX	Dec13		Hit	7	30.66									30.51						
ECX	Dec14													31.22						
ECX	Dec08/Dec09	+	Hit	20	-1.06	-1.04	5	Lift	-1.04	-1.09	-1.05	87	-1.05	-1.05						
ECX	Dec09/Dec10	+	Hit	5	-0.88	-0.80	10	Lift	-0.81	-0.86	-0.81	20	-0.83	-0.88						
ECX	Dec10/Dec11	+	Hit	5	-1.18	-1.03	10	Lift						-1.05						
ECX	Dec11/Dec12	+	Hit	10	-1.41	-1.29	10	Lift						-1.32						
ECX	Dec12/Dec13					-1.44	10	Lift						-1.53						
ECX	Dec13/Dec14													-0.71						
ECX CER	Dec08	+	Hit	10	20.30	20.45	20	Lift	20.82	20.34	20.49	1585	20.67	20.42						
ECX CER	Dec09	+	Hit	10	21.00	21.22	20	Lift	21.55	21.25	21.20	1323	21.49	21.17						
ECX CER	Dec10	+	Hit	10	21.40	21.63	10	Lift	0.00	0.00		0	0.00	21.59						
ECX CER	Dec11	+	Hit	10	21.71	21.95	20	Lift	0.00	0.00	21.95	25	0.00	21.92						
ECX CER	Dec12	+	Hit	10	22.61	22.95	10	Lift	0.00	0.00		0	0.00	22.78						
ECX CER	Dec08/Dec09	+	Hit	25	-0.77	-0.70	20	Lift	-0.73	-0.80	-0.74	1250	-0.75	-0.75						
ECX CER	Dec09/Dec10	+	Hit	10	-0.44	-0.36	20	Lift						-0.42						
ECX CER	Dec10/Dec11	+	Hit	25	-0.40	-0.31	10	Lift						-0.33						

Gas Oil Futures - ARA - Oct08, 1 @ 964.00 (15:33:33 BST) ↑

Gas Oil Futures - ARA - Oct08, 1 @ 964.00 (15:33:33 BST) ↓

WTI Crude Futures - WTI - Dec08, 1 @ 105.90 (15:33:32 BST) ↑

Gas Oil Futures - ARA - Dec08, 1 @ 961.25 (15:33:32 BST) ↓

Gas Oil Spr - ARA - Oct08/Dec08, 1 @ 2.25 (15:33:32 BST) ↓

Gas Oil Futures - ARA - Oct08, 1 @ 963.50 (15:33:32 BST) ↓

Brent Crude Spr - North Sea - Feb09/Mar09, 1 @ -0.63 (15:33:32 BST) ↓

Brent Crude Futures - North Sea - Feb09, 1 @ 105.61 (15:33:32 BST) ↓

Brent Crude Futures - North Sea - Mar09, 1 @ 106.24 (15:33:32 BST) ↓

WTI Crude Futures - WTI - Mar09, 1 @ 106.35 (15:33:32 BST) ↓

15:33:33 BST Users: 9858



## CER / ERU Origination like a resource Exploration & Production business...

- Find the reserve of “emission reductions”
- Negotiate access to these reductions: joint development agreement
- Develop the reduction project
- Manage the CDM/JI project approval process
- Physically issue the CERs / ERUs
- Monetise and share value with asset owner



# CDM: How it basically works

## Supply - Non-Annex I

## Demand - Annex I

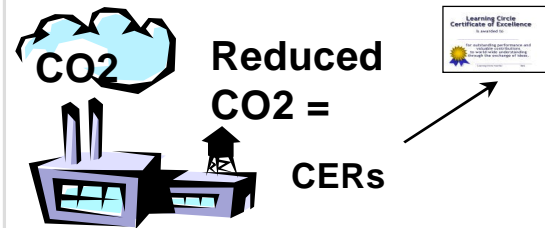

After Project

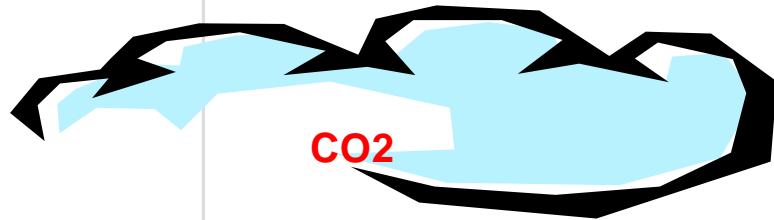

CO2

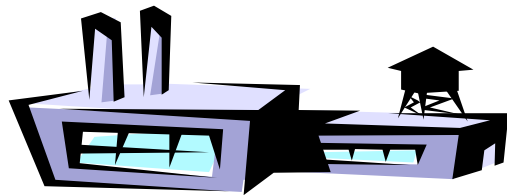

Before Project

CO2 Emissions

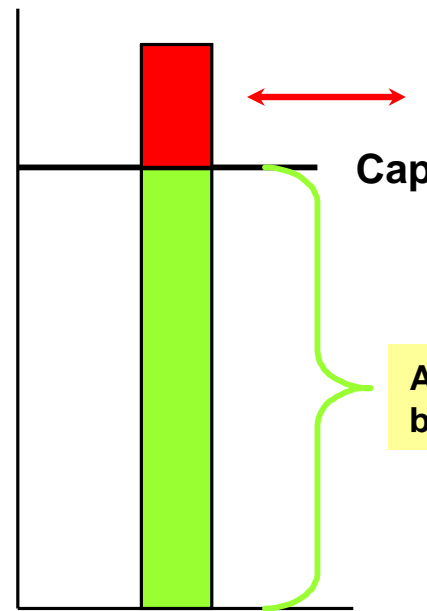

Unit to offset excess



## There are two ways to generate Kyoto credits saleable to companies for compliance under the EU ETS

### CLEAN DEVELOPMENT MECHANISM (CDM)

- Set up projects in developing (non-Annex I) countries to reduce carbon emissions and contribute to sustainable development
- **Certified Emission Reduction (CER)** credits are issued for each tonne of CO<sub>2</sub>e abated relative to a project baseline

### JOINT IMPLEMENTATION (JI)

- Set up projects in developed (Annex I) countries to reduce carbon emissions and contribute to sustainable development
- **Emission Reduction Unit (ERU)** credits are issued for each tonne of CO<sub>2</sub>e abated relative to a project baseline

***Both CERs and ERUs can be used by countries and governments for compliance under the EU ETS and Kyoto Protocol***



# Although developing a CDM or JI project is complex, there is a well-defined process

## TYPICAL CDM PROJECT PROCESS

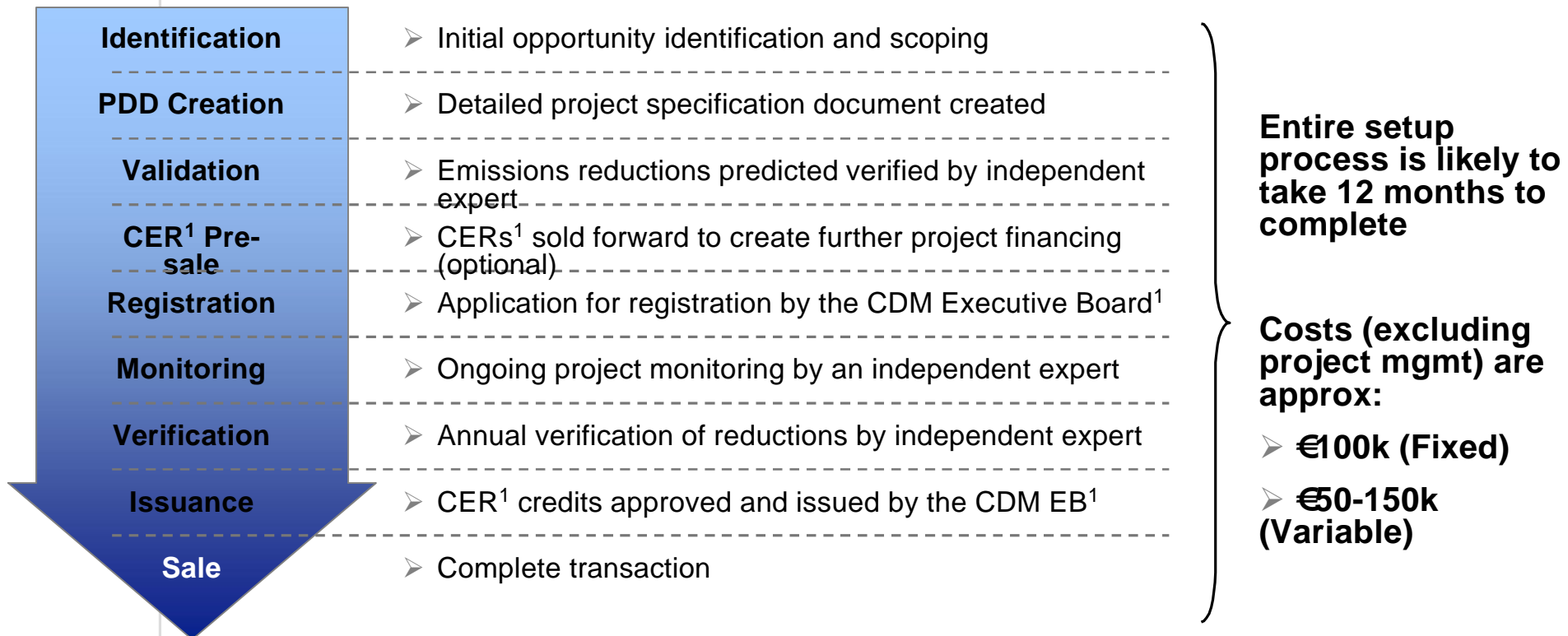

1. The credits arising from JI projects are called ERUs.
2. Some JI projects can be approved in country rather than by the CDM EB



Displaying projects: All Public Registered Review Requested Under Review

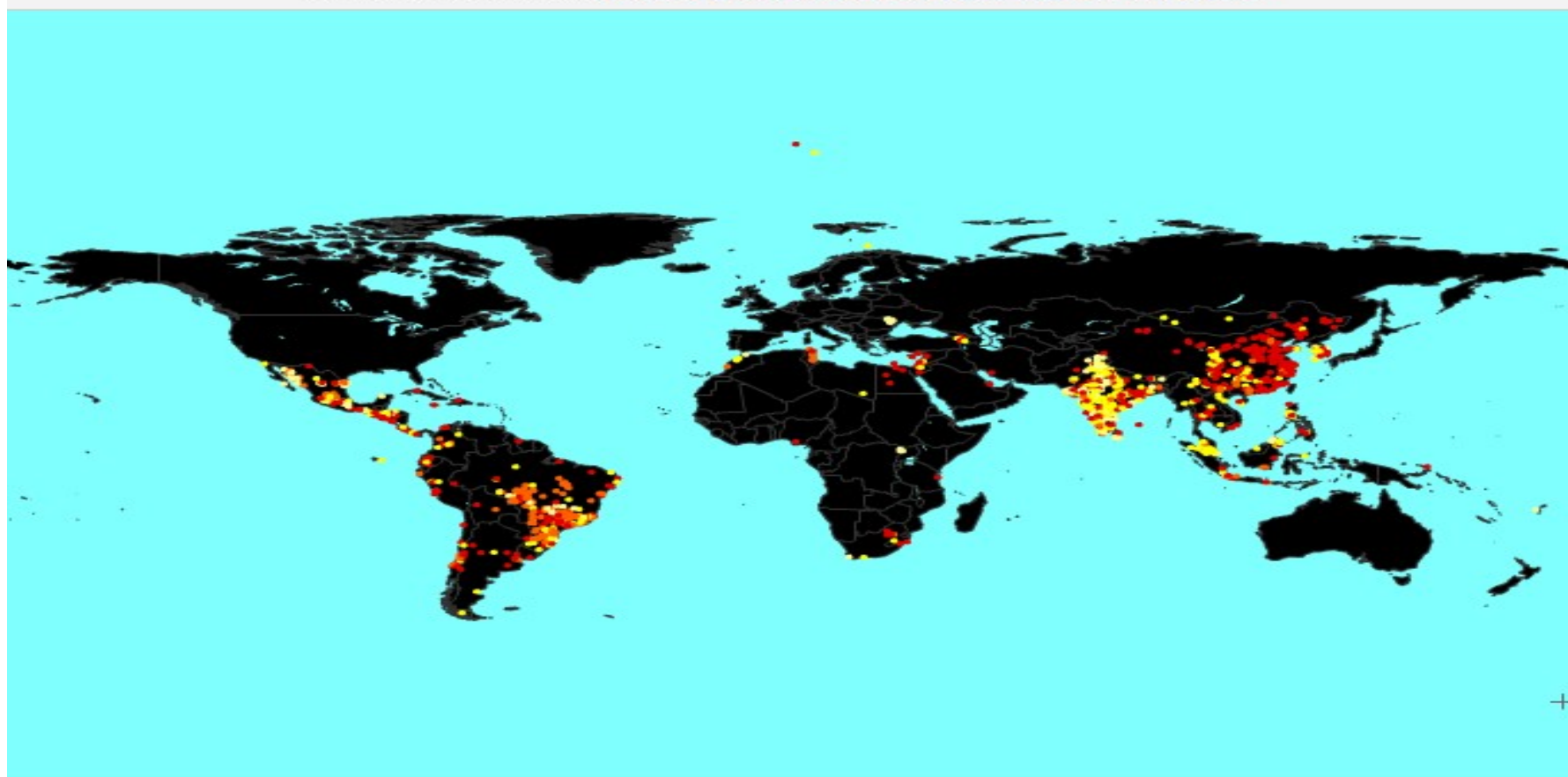

The boundaries and names shown and the designations used on this map do not imply official endorsement or acceptance by the United Nations

If you cannot see the map, you need to **get the latest Macromedia Flash player** plugin installed in your browser

legend

- = CDM project, Large scale, one location
- = CDM project, Large scale, several locations
- = CDM project, Small scale, one location
- = CDM project, Small scale, several locations

Source: <http://cdm.unfccc.int/Projects/MapApp/index.html> (as of 27 Mar 09)



# Risk Management / Trading STRATEGIES

Where is your business?

## Risk

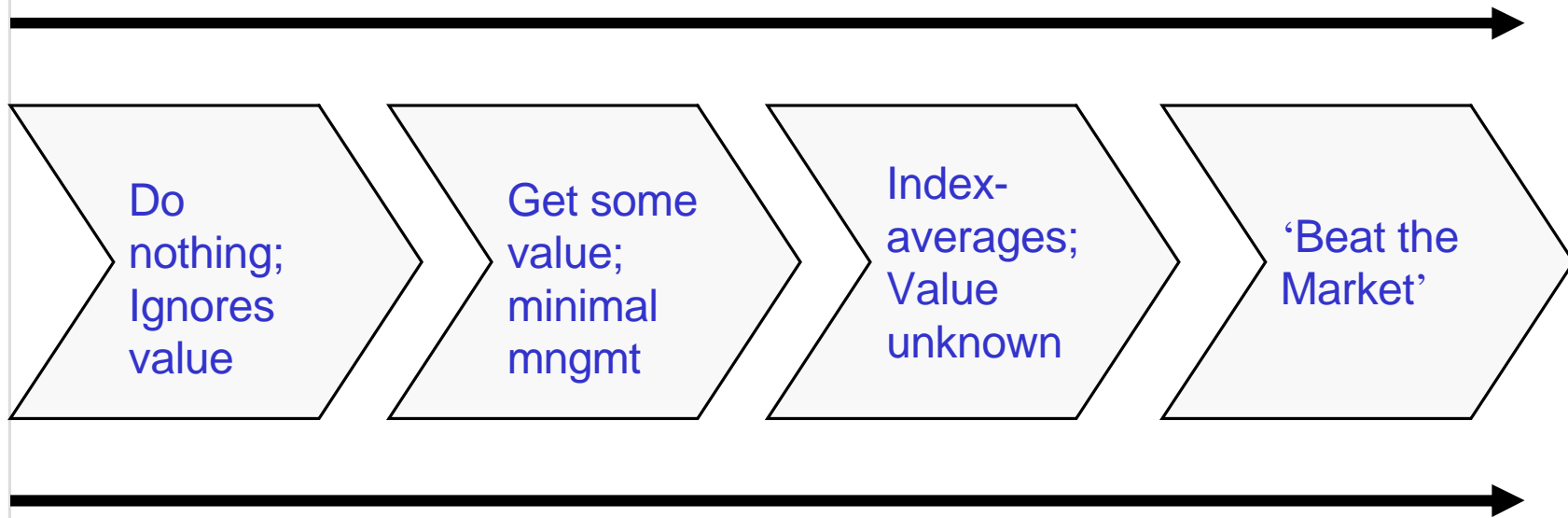

## Potential Value



## CERs and ERUs for Compliance

- Installations can use EUAs (EU Allowances), CERs (Certified Emission Reductions - CDM), ERUs (Emissions Reduction Units – JI) for compliance
  - Each gives the right to emit one tonne of CO<sub>2</sub>e
- Limit on the amount of CERs or ERUs that can be used for compliance (known as ‘Supplementarity Limit’ or ‘Conversion Capacity’)
  - For aviation = 15% of 2012 emissions and at least 1.5% / annum from 2013-2020
- Market Value: CERs & ERUs trading at a discount to EUAs
- Installation can buy CERs / sell EUAs (same volume, same vintage) to capture the value of that spread and reduce the cost of compliance / maximise value of allowance portfolio.
- Does NOT affect compliance as installation is simply substituting one compliance mechanism (EUA) for another (CER or ERU)



## Indicative cost of EUAs (EU Allowances) or CERs (Certified Emission Reductions)

€/Tonne				
Year	EUA	CER	CER/EUA	
2009	14.29	12.13	-	2.16
2010	14.92	12.15	-	2.77
2011	15.50	12.34	-	3.16
2012	16.47	12.70	-	3.77
<b>2009-2012</b>	<b>15.30</b>	<b>12.33</b>	<b>-</b>	<b>2.97</b>

NOTE: The spread between CERs (or ERUs) and EUAs is usually quoted as the 'CER / EUA Spread'. A negative value implies that CERs are less expensive than EUAs



# CER / EUA Spread

## Step-by-step

- Installation X has an allowance of 1 million tonnes/annum in Phase II (2008-2012)
  - 1 million x 5 years = 5 million tonnes
- Supplimentarity = 10%
  - 1 million x 10% x 5 years = 500k CERs in Phase II
- Installation buys the CER/EUA Spread
  - Buy 500k CERs @ €12.33 / Sell 500k EUAs @ €15.30
  - Net compliance position is the same
  - Savings = €5.44/tonne x 500k tonnes = €1.483 million
- **The spread is the key, NOT the outright value of each 'leg'**
  - If EUAs and CERs drop, can buy CERs cheaper, but can't sell the EUAs for the higher amount (and vice versa for rising values).
  - One's view of the spread value is the determinant of when to do the trade.



# Time-spread: Turning the forward curve into 'cheap money'



## Time-spread: Overview

- When the contango (increase in future price vs current price) of the forward curve is less than the cost of money (either the interest rate, or your internal cost of borrowing)...
  - Sell prompt EUA (Jun 2009)
  - Buy deferred EUA (Jan 2013)
- Receive € 'x' in 2009 and invest at alternative cost of money
- Pay € 'y' in 2013
- Net difference is the profit / loss
- Does not affect compliance due to intra-phase borrowing of allowances (see below slide for example)
- **For Aviation**, you would be able to do this within 2012 if the arbitrage opportunity continues, or in Phase III (2013-2020)
  - Example: Airline X receives 1 million EUAs in Feb 2012 and sells spot, and simultaneously agrees to buy them back in Dec 2012
  - This intra-year timespread can be done each year or across multiple years



## Time-spread: Step-by-Step

Prices are illustrative only

Year	EUA €/t	% Increase (aka 'contango')
Spot (Jun 09)	14.02	
Dec-09	14.29	1.93%
Dec-10	14.92	4.41%
Dec-11	15.50	3.89%
Dec-12	16.47	6.26%



# Time-spread: Step-by-Step

Prices are illustrative only

- Sell 1 million tonnes Spot (June09)/Dec12 spread
  - Sell Spot @ €14.02/t
  - Buy Dec12 @ €16.47/t
- Receive €14.02 million from spot sale
- Invest money at alternative cost/value of money
  - Assuming an alternative cost / value of money to the airline of 7% (i.e. – you can use the money and get a 7% return or would have to pay 7% to borrow money externally)
  - Compounds to roughly €17.76 million by Dec12
- Pay €17.52 million in Dec12
- Profit (not present-valued) = € 1.294 million
  
- NOTE: Even if one uses a lower value of money (thereby reducing the profit), many companies would still be interested in this transaction simply for the upfront cash that it generates



# Time-spread: Step-by-Step

Feb08 – Receive  
2008 EUAs

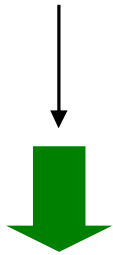

Feb09 – Receive  
2009 EUAs

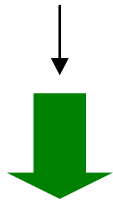

Feb10 – Receive  
2010 EUAs

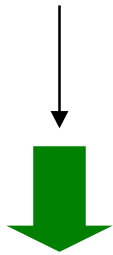

Feb11 – Receive  
2011 EUAs

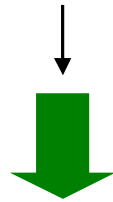

Feb12 – Receive  
2012 EUAs

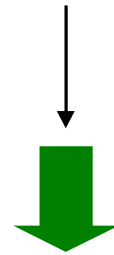

**Dec12 – Received  
purchased Dec2012 EUAs  
and pay cash (and ‘cash-  
in’ investment from 2008)**

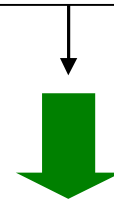

Feb	Feb	28+1	Feb	Apr	Feb	Apr	Feb	Apr	Feb	Apr	Dec	Apr
2008			2009		2010		2011		2012		2013	

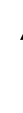

**Sell 2008 EUAs: Receive cash  
and invest at Euribor (and  
simultaneously agree  
purchase price for Dec12  
EUAs)**

Apr09– Surrender 2009  
EUAs for 2008  
monitoring period

Apr10– Surrender 2010  
EUAs for 2009  
monitoring period

Apr11– Surrender 2011  
EUAs for 2010  
monitoring period

Apr12– Surrender 2012  
EUAs for 2011  
monitoring period

Apr13– Surrender  
purchased 2012 EUAs  
for 2012 monitoring  
period



# Contractual Relationships

## Master Agreement

This doesn't commit Counterparty nor Shell to anything, but instead provides an umbrella agreement that allows us to conduct multiple trades

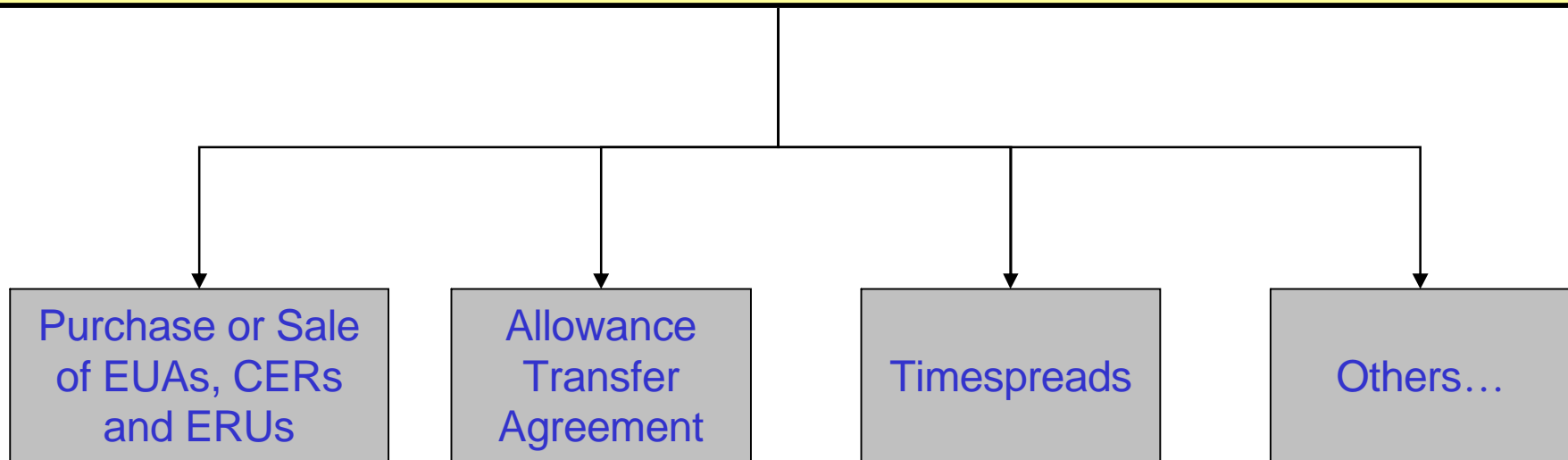

# Disclaimer

Approved for issue by Shell International Trading and Shipping Company Ltd.

Shell International Traing and Shipping Company Ltd. is authorised and regulated in the UK by the Financial Services Authority (“FSA”)

In the UK, certain products and services provided by Shell Trading are directed exclusively at market professionals and institutional customers who qualify as Eligible Counterparties or Professional Customers and are not available to Retail customers, as defined by the FSA. Outside the UK local regulations or restrictions may apply.

The information contained in this presentation is provided to you for information purposes only and is not to be used or considered as an invitation to trade or a formal offer in respect of any of the products or services mentioned.

Shell International Trading and Shipping Company Ltd. makes no representation or warranty of any kind concerning the accuracy of the information in this publication and disclaims all liability whatsoever (whether in negligence or otherwise) for the same.

**Shell Group affiliates are not acting as an advisor to the recipient of this information, and the ultimate decision to proceed with any transactions rests solely with the recipient of this information.** Therefore, prior to entering into any proposed transaction, the recipient of this information should determine, without reliance upon Shell or its affiliates, the economic risks and merits, as well as the legal, tax, and accounting characterizations and consequences, of the transaction and that it is able to assume their risks.

